



**ADJUSTABLE SET POINT AIR PRESSURE SENSING SWITCH WITH MANUAL RESET**

**APPLICATION**

The **Model AFS-460-112** is a general purpose proving switch with a **manual reset** feature that requires operator intervention whenever it actuates. It can be used to sense positive, negative, or differential air pressure in HVAC and Energy Management applications that require operator interface. The **AFS-460-112** is equipped with convenient barbed sample line connectors that accept flexible tubing.

**GENERAL DESCRIPTION & OPERATION**

The plated housing contains a diaphragm, a calibration spring and a snap-acting SPST-NC switch with a manual reset button.

The barbed sample line connections located on each side of the diaphragm accept flexible tubing.

An enclosure cover guards against accidental contact with the live switch terminal screws and the set point adjusting screw. The enclosure cover will accept a 1/2" conduit connection.

**MOUNTING (SEE FIGURE 1)**

Select a mounting location that is free from vibration. The **AFS-460-112** must be mounted with the diaphragm in any vertical plane in order to obtain the lowest specified operating set point. Do not mount with the sample line connections in the "up" position. Surface mount via the two 3/16" diameter

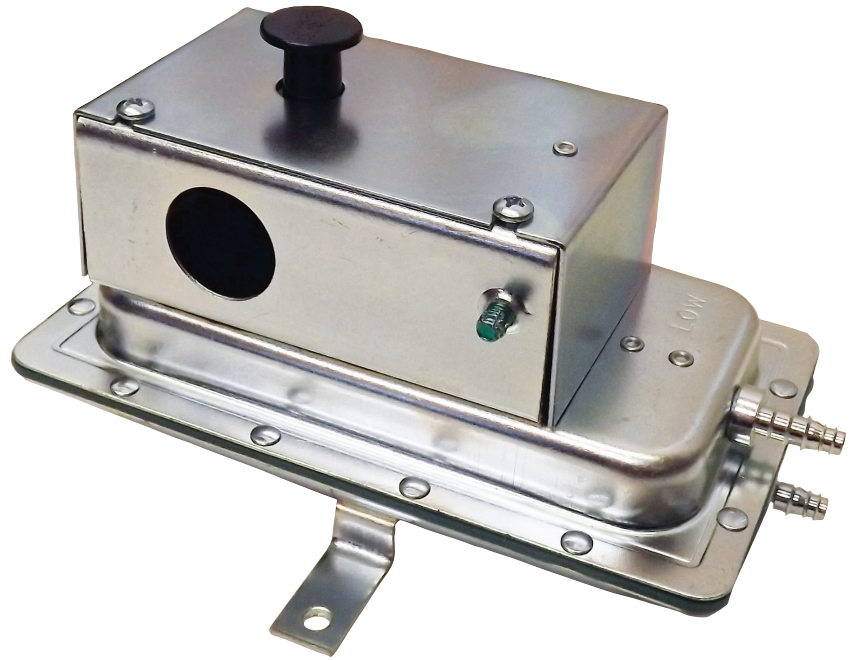

**AIR SAMPLING CONNECTION (SEE FIGURE 2)**

holes in the integral mounting bracket. The mounting holes are 3-7/8" apart.

The sample line connections located on each side of the diaphragm accept flexible tubing by means of barbed 1/4" slip-on connections. For sample lines up to 10 feet, 1/4" OD tubing is acceptable. For lines up to 20 feet, use 1/4" ID tubing. For lines up to 60 feet, use 1/2" ID tubing.

Locate the sampling probe a minimum of 1-1/2 duct diameters downstream from the air source. Install the sampling probe as close to the center of the airstream as possible. Refer to **Figure 2** to identify the high pressure inlet (**H**) and the low pressure inlet (**L**). Select one of the following five application options, and connect the sample lines as recommended.

**POSITIVE PRESSURE ONLY:** Connect the sample line to inlet **H**; inlet **L** remains open to the atmosphere.

**NEGATIVE PRESSURE ONLY:** Connect the sample line to inlet **L**; inlet **H** remains open to the atmosphere.

**TWO NEGATIVE SAMPLES:** Connect the higher negative sample to inlet **L**. Connect the lower negative sample to inlet **H**.

**TWO POSITIVE SAMPLES:** Connect the higher positive sample to inlet **H**. Connect the lower positive sample to inlet **L**.

**ONE POSITIVE AND ONE NEGATIVE SAMPLE:** Connect the positive sample to inlet **H**. Connect the negative sample to inlet **L**.

(Figure 1)

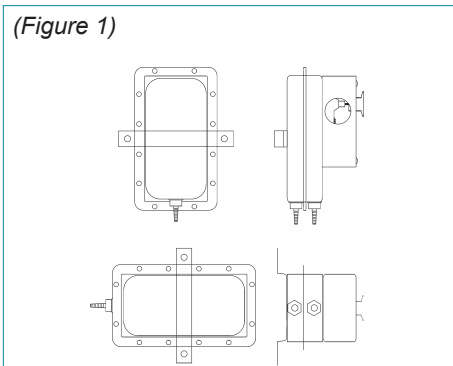

(Figure 2)

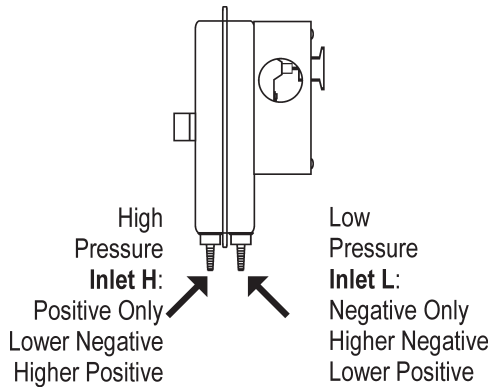

(Figure 3)

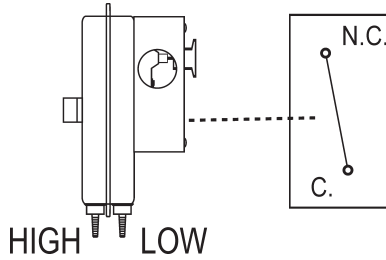

### ELECTRICAL CONNECTIONS (SEE FIGURE 3)

Before pressure is applied to the diaphragm, the switch contacts will be in the normally closed (NC) position as shown in **Figure 3**.

The snap switch has screw top terminals with cup washers. Wire alarm or control application as shown in **Figure 4**.

(Figure 4)

To prove excessive or insufficient air flow or pressure:

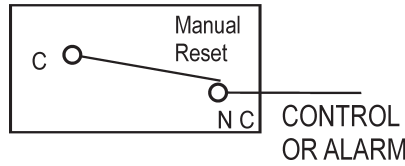

### FIELD ADJUSTMENT

The adjustment range of an **AFS-460-112** Air Switch is  $0.40 \pm 0.06$  w.c. to 12.0" w.c. To adjust the set point, turn the adjusting screw counterclockwise until motion has stopped. Next, turn the adjusting screw four complete turns in a clockwise direction to engage the spring. From this point, the next ten turns will be used for the actual calibration. **Each full turn represents approximately 1.16" w.c.**

**Please note:** To properly calibrate an air switch, a digital manometer or other measuring device should be used to confirm the actual set point.

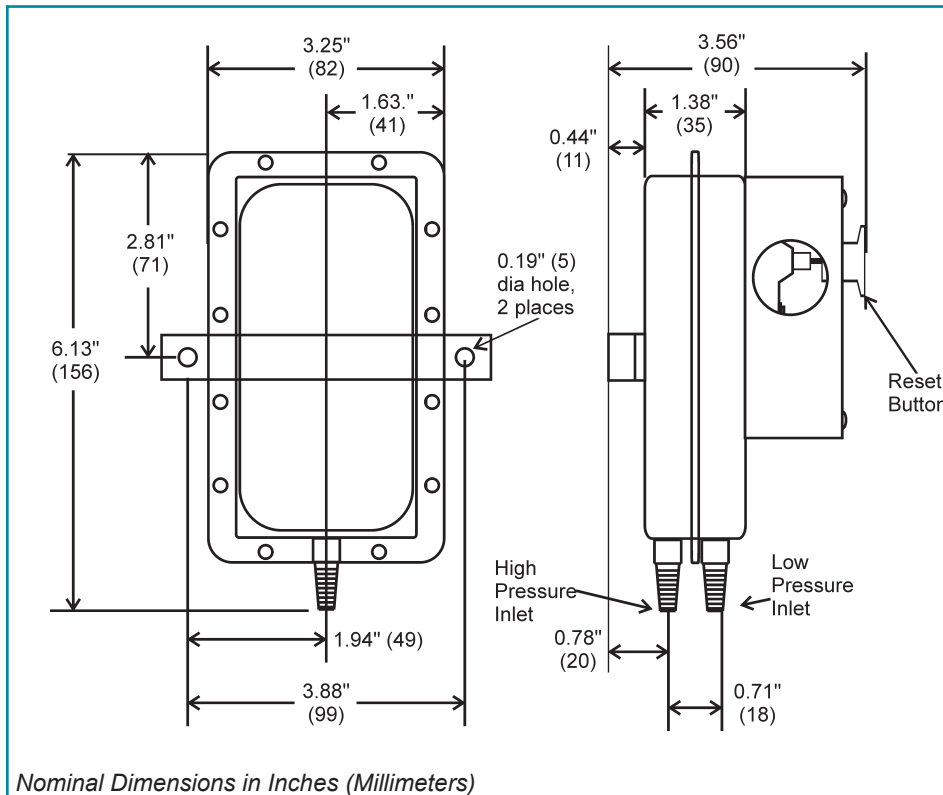

### SPECIFICATIONS

#### MODEL AFS-460-112 AIR PRESSURE SENSING SWITCH WITH MANUAL RESET FEATURE

##### Mounting Position:

In order to meet lowest operating specifications, mount with the diaphragm in any vertical plane.

##### Set Point Range:

$0.40 \pm 0.06$ "w.c. to 12.0"w.c.

##### Field Adjustable

##### "Operate Range":

0.46"w.c. to 12.0" w.c.

##### Measured Media:

Air

##### Maximum Pressure:

$\frac{1}{2}$  psi (0.03 bar)

##### Life:

Exceeds UL-recognized mechanical endurance test of 6,000 cycles minimum at 0.5 psi maximum pressure each cycle and at maximum rated electrical load

##### Electrical Rating @ 60 Hz.:

15A @ 125, 250, or 277 VAC.

$\frac{1}{2}$  A @ 125 VDC,  $\frac{1}{4}$  A @ 250 VDC.

$\frac{1}{4}$  hp @ 125 VAC;  $\frac{1}{2}$  hp @ 250 VDC.

##### Contact Arrangement:

SPST-NC (manual reset)

##### Electrical Connections:

6-32 screw-top terminals with cup washers

##### Conduit Connection:

$\frac{7}{8}$ " diameter opening accepts  $\frac{1}{2}$ " conduit

##### Sample Line Connections:

Two barbed  $\frac{1}{4}$ " connectors accept flexible tubing.

##### Approval and Recognition:

UL, CSA, CE

##### Shipping Weight:

1.2 lbs.

##### Accessories:

- Sample line probes
- Orifice plugs (pulsation dampers)